

12VDC AND 24VDC BATTERY BACK-UP POWER SUPPLY

ADA 60W DUAL



Features

- » 12VDC and 24VDC battery back-upped supply
- » Compact size
- » Easy to install
- » EMC EN55022B
- » Mains connection with plug or screw terminal
- » Tamper Switch
- » Temperature compensation
- » Power fail relay alarm
- » Low Voltage Disconnection

ADA

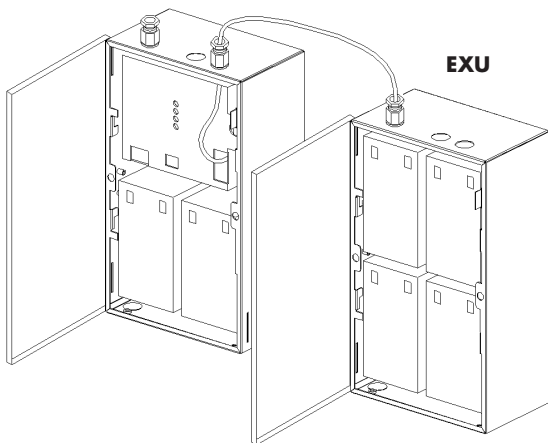

More battery capacity available with EXU extra battery unit

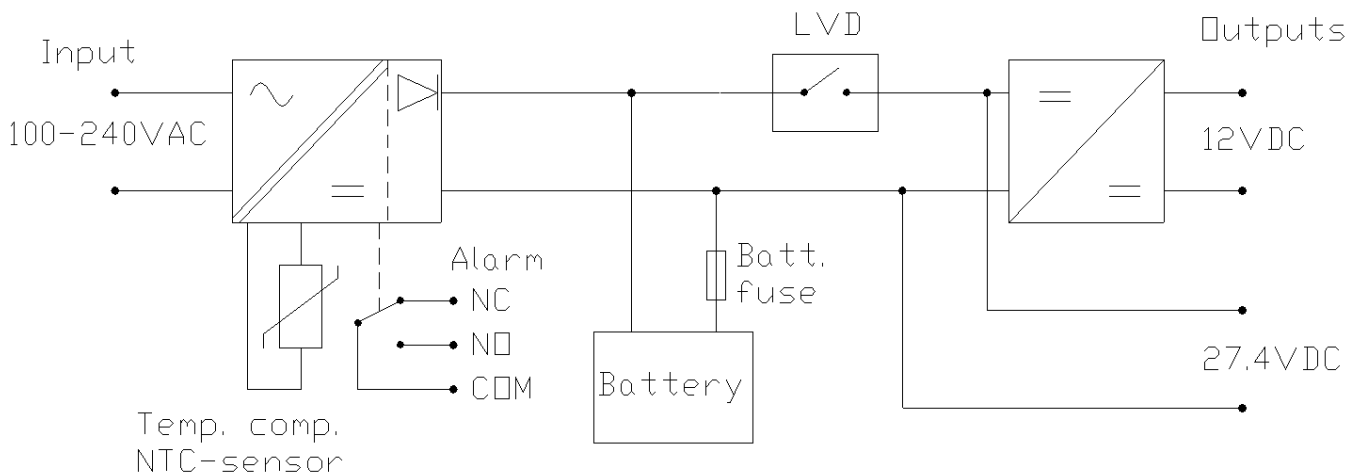

POWER SUPPLIES WITH BATTERY BACK-UP

Type *) See x below	Input voltage	Output 1	Output 2	Total Power	Battery Capacity	Installation / dimensions (Width x Height x Depth)
ADA804x	90...264VAC	27.4VDC 2.2A	12VDC 2A	Max 60 W	24V 7Ah	Wall / 188 x 317 x 110mm
EXU709x	External battery unit 24VDC 14Ah					Wall / 188 x 317 x 110mm

x selection code: 0 = with batteries / without tamper switch 1 = without batteries / without tamper switch
 2 = with batteries / with tamper switch 3 = without batteries / with tamper switch

INPUT

Input voltage range	90...264 VAC
Frequency	45...65Hz
Efficiency (U _{in} = 230 VAC, 100% 24VDC load, no load at 12VDC)	AC to 24VDC 84%, 24VDC to 12VDC 86%
Input current (P _{out} = 60W)	0,7A @ 230VAC, 1,2A @ 120VAC
Safety	EN 60950 Class 1
Isolation:	input / ground 1500 VAC RMS 50Hz, 1min input / output 3000 VAC RMS 50Hz, 1min output / ground 500 VAC
EMC	EN 55022 class B
Inrush-current	<30A @ Ta=25 °C (<50A @ Ta=55 °C)
Overvoltages	Protected by 275V 72J VDR-resistor
Input fuse	T3.15A high breaking
Approvals	CE-marking

OUTPUT 1 27.4VDC

Charging voltage (50% load)	27.4 V
Output adjustment (user adjustable)	21...29 V
Ripple voltage (f = 20Hz...300kHz, T _{amb} = 25°C)	<10mVrms
Load regulation (I _{out} = 10...100%)	± 0.5 %
Dynamic regulation (I _{out} = 10<□>90%)	< 3% for <1ms
Line regulation (U _{inmin} ...U _{inmax})	± 0.1 %
Output current at charging voltage	2.2 A
Current limit, charger	3.7 A
Short circuit current limiting, battery	Fuse T3.15A

OUTPUT 2 12VDC (DC/DC conversion from 24VDC)

Nominal output voltage fixed	12Vdc
Ripple voltage (T _{amb} = 25°C)	< 25mVrms
Load regulation (I _{out} = 10...90%)	± 0.5%
Pulse load overshoot (I _{out} = 10<□>90%)	< 4%
Line regulation (U _{inmin} 20V...U _{inmax} 30V)	± 0.7%
Output current	2A
Current limit	<2,5A
Max start-up current	2A at resistive load and 1.2A at constant current mode

BATTERY BACK-UP

Battery capacity	24 VDC 7Ah
Battery type Genesis / Yuasa	NP 7-12 7Ah 12V
Battery back-up time (typical)	50W / 3h, 10W / 15 h
Temperature compensation for battery	NTC-resistor 2k2
Low Voltage disconnection for battery positive line	release at 20V, reconnection at 23.5VDC
Battery fuse in negative output line	T3.15A

INDICATIONS AND ALARMS

Charger output OK	Green LED is on
Power Fail (mains or module failure), 24VDC module only	Potential free open and closing relay contacts; Relay 24VDC/0.3A or 30VAC/0.5A
Door open tamper switch (if ordered)	Micro switch, open and closing contact

MECHANICS

Dimensions	See table on first page
Mounting	Wall / screw mounting
Weight	Without batteries 2.3kg, with batteries 8kg
Locking of the cover	By tool (screwdriver)
Enclosure	Steel case IP21

ENVIRONMENTAL

Operation temperature	-40°C...+55 °C without batteries -20°C...+45 °C with standard batteries
Humidity	85% RH IEC68-2-30
Ventilation	Natural convection

CONNECTORS

Input	2.5mm ² 3-pole screw terminal (L-N-PE) Inlet through the cover, 1.5m power cord included
Output 12VDC, 27.4VDC	2.5 mm ² screw terminals (+, -), Inlet through the cover
Battery	2.5 mm ² 2-pole screw terminal (+, -), internal connection
Power fail alarm and battery temp.comp	2.5 mm ² 5-pole screw terminal (Alarm NO, NC, COM, Temp.comp), Inlet through the cover, NTC resistor included in installation kit



Connectors in charger module
(OUT + and – for internal connection)

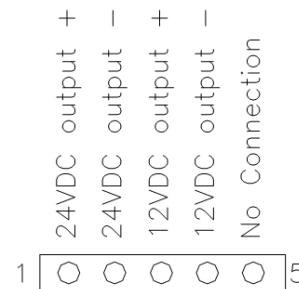

Output connectors

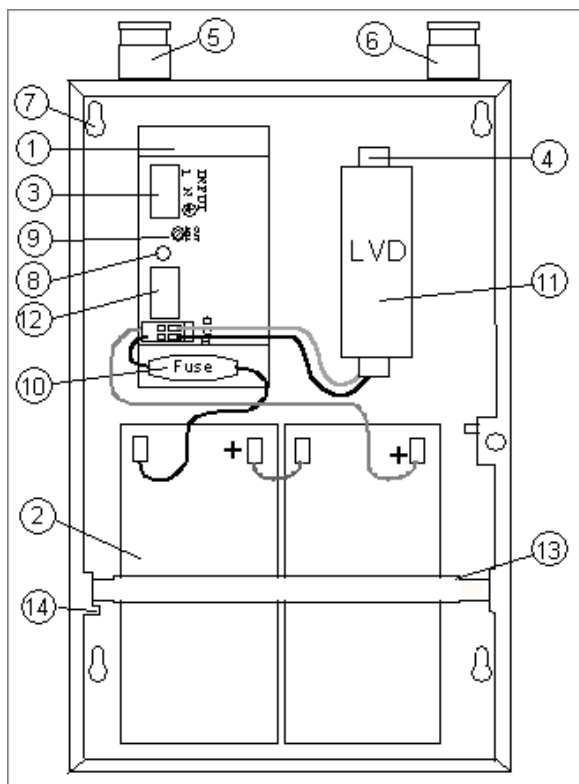

1. Charging unit
2. Batteries 2 pcs
3. Input connector
4. Output connector
5. Cable entry (input)
6. Cable entry (output)
7. Wall mounting holes
8. Output OK LED
9. Output voltage adjustment
10. Battery fuse
11. LVD & 12V converter
12. Alarm connector
13. Mounting bar for batteries
14. Locking plate, bend to open / lock

INSTALLATION

Make sure that the power plug is disconnected from the mains network and the battery is disconnected from load terminals before connecting the load cables. In case of possible short circuit in load side it is recommended to turn first power on only for the charger (battery disconnected). If all is OK, connect the battery and system is ready for use.

OUTPUT VOLTAGE ADJUSTMENT

24VDC output voltage can be adjusted with the multi turn potentiometer located on inside of cabin on the front side of the power module (10). Maximum output power (60W) is available within the full voltage adjustment range. 12VDC output is not adjustable.

LED

A green LED (9) indicates that the 24Voutput of the charger module is healthy. For 12V output is not LED indicator.

OUTPUT OVERCURRENT PROTECTION

The battery is protected against over current by battery fuse (12). 24VDC charging unit includes automatic, self-resetting electronic current limiting. 24/12VDC converter have electronic current protection.

BATTERY DEEP DISCHARGE PROTECTION

The battery is protected against deep discharge by low voltage disconnection switch. The switch opens when battery voltage drops below 20VDC and connects again when battery voltage raises over 23,5VDC.

ALARM RELAY

The potential free alarm output indicates if the charger's 24VDC output is healthy. The alarm signal is activated at AC fail and charger fail cases. Both normally open and normally closed signals are presented. If the 24V output is healthy, the relay is energised and pins ALARM COM and ALARM NO are short circuit. If the unit fails the relay contacts will changeover and ALARM COM and ALARM NC will be short circuit. For 12VDC there is no relay alarms.

TAMPER SWITCH

A micro-switch (13) alarm indicates if the door of the power supply is open. If the door is closed, DOOR ALARM pins are short circuit.

TEMPERATURE COMPENSATION

Temperature compensated charging provides the optimum float charge voltage to increase batteries lifetime. To utilize this feature it is necessary to install a sensor across the pins 4 and 5 on the charger's output connector. It is also necessary to set the TEMP COMP jumper on the front panel to ON position. (Note: The output voltage should be adjusted with the jumper in the OFF position, this simulates 25 °C temperature).

Temp. comp. sensor (11) is a 2.2k ohm NTC resistor, e.g. Epcos B57164K0222. The sensor should be installed near the batteries. The sensor is galvanically connected to the + output. It is recommended to keep the sensor connection as short as possible. NTC resistor is included with device.

WARNING!

Dangerous voltages, capable of causing death, are present in this equipment. Do not remove the charger's cover. No operator serviceable parts inside. Refer servicing to qualified service personnel. Batteries contain high energy, do not short circuit! The charger is not protected against reverse battery polarity. Disconnect mains before changing batteries.