

SEALED, 400W, IT AND 2XMOPP MEDICAL RATED AC-DC POWER SUPPLY

DDP / MDP400 SC Series



Certifications



Applications

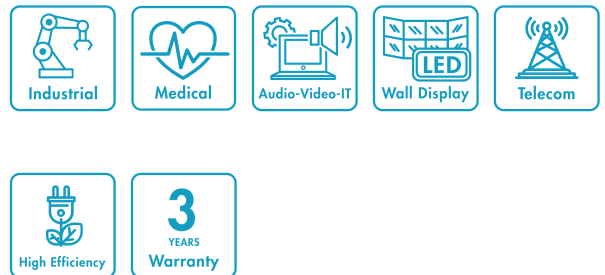

FEATURES

- » Universal input voltage range (90 – 264 V_{AC})
- » Input surge current limiting
- » 400 W rated power (440 W peak up to 10 s)
- » High efficiency up to 94%
- » Low stand-by consumption (<0.5 W)
- » 12, 24, 36 or 48 VDC standard output voltages
- » Active PFC, EN61000-3-2 compliant (Class C, >25 % load).
- » Low earth / touch leakage current
- » Over temperature protection
- » OV, OC and SC protections.
- » Stand-by +5 V, 2 A and auxiliary / fan 12 VDC, 1 A outputs.
- » Remote On / Off signal
- » Power good and remote sense signals
- » Sealed, potted package IP67 rated, fits 1U applications
- » ANSI/AAMI ES60601-1 and IEC/EN 60601-1 3rd ed. Compliant to 2XMoPP, BF appliances compatible
- » EN 60601-1-2 4th ed. for immunity compliance
- » UL/IEC 60950-1 and UL/IEC 62368-1 safety approval
- » RoHS 3 compliant (Directive 2015/863/EU)
- » Medical version compatible with 4000 m altitude operation

MARKET SEGMENTS AND APPLICATIONS

- » Industrial and Process Control
- » Telecommunications
- » Test and Measurement Equipment
- » Medical applications

PRODUCT DESCRIPTION

DDP400 and MDP400, SC series, are sealed, full potted, compact, high efficiency, small form factor AC-DC power supplies. The series provide a steady 400 W of regulated DC power through the full 90 to 264 V_{AC} input range. A 3.27" x 8.34" x 1.65" form factor, enable designers to integrate it into 1U applications. By converting energy at a typical 94% efficiency, the DDP400 and MDP400 SC series generate less heat facilitating thermal management in space constrained environments, resulting in very high reliability. Both the DDP and MDP SC series are available in four standard output voltages: 12, 24, 36, 48 V_{DC}, offer an auxiliary 12 V_{DC} and a stand-by 5 V_{DC} outputs. Available control signals include Power Good (Power_OK), remote On/off (PS_ON) and remote sense (+RS). The sealed and full potted package allows an IP67 ingress protection index, and can be installed in contact with thermo-conductive part of the system so to transfer heat by conduction, therefore, enhancing performances. When conduction cooled, or convection cooled with its optional heat sink assembled, the SC series can deliver full output power from -20 to 50 °C. It can operate up to 70 °C with de-rating and is capable to start up from – 30 °C. Protection features do include fuse on each AC lines, input under-voltage lockout (IUV), output over-current (OC), output short-circuit (SC), output over-voltage (OV) and over-temperature (OT). The MDP400 range comply with the 3rd edition of the UL/IEC 60601-1 safety standards for medical equipment offering 2x MoPP protection grade and BF appliance compatibility. The DDP400 range comply with the UL/IEC 60950-1 and UL/IEC 62368-1 standards for Audio Video and IT equipment. Both the series meets the EN55032 EMC limits of Class B for conducted and radiated emissions as well as the IEC/EN 61000-3 and IEC/EN 61000-4 EMC standards. MDP400 comply with EN 60601-1-2 4th ed. for immunity.

Model Coding and Output Ratings

Model Grade and Output Power	Output Nominal Voltage	Package/Fan Options	Medical protection grade
	12 V _{DC} : US12-	Sealed Conduction/Convection Cooling: SC-	Means of Patient Protection PP (* Only applicable on Medical range)
ITE: DDP400-	24 V _{DC} : US24-		
Medical: MDP400-	36 V _{DC} : US36-		
	48 V _{DC} : US48-		

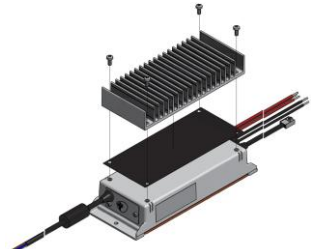
D	DP400	-	US	-	SC	-	(PP)*	DDP-HS	Heat sink can be ordered as an accessory using the code:	
									12	
									24	
									36	
M								Mounting kit includes 4x screws (M4x10), and the thermally conductive graphite sheet		

Model Number	V1 [V]	I1 ¹ Convection No heat sink (A)	I1 ² Conduction Heat sink (A)	V1 ³ Ripple (mV)	V2 (V)	I2 ¹ Rated (A)	V2 ³ Ripple [mV]	5 V _{SB} (V)	15V _{SB} ¹ Rated (A)	5V _{SB} ³ Ripple (mV)
DDP/MDP400-US12-SC (-PP)	12	29.2 4	33.3	120	12	1	240	5	2	50
DDP/MDP400-US24-SC (-PP)	24	14.6 4	16.7	240	12	1	240	5	2	50
DDP/MDP400-US36-SC (-PP)	36	9.7 4	11.1	360	12	1	240	5	2	50
DDP/MDP400-US48-SC (-PP)	48	7.3 4	8.3	480	12	1	240	5	2	50

¹ The combined output power of V1, V2 and 5 V_{SB} for all models, when convection cooled and V_{IN} ≥ 180 V_{RMS}, must not exceed 350 W up to 50 °C, and 240 W at 70 °C ambient temperature. See de-rating curves below.

² The combined output power of V1, V2 and 5 V_{SB} for all models, when conduction cooled or convection cooled with heat sink mounted, must not exceed 400 W up to 50 °C, and 300 at 70 °C ambient temperature.

³ Peak-to-Peak measured at 20 MHz Bandwidth.

⁴ Convection / Conduction output current ratings, do refer to <50 °C ambient temperature and V_{IN} ≥ 180 V_{RMS}.

⁵ In any case, the chassis hot spot temperature TC should never exceed 90 °C.

Input Specifications

Specification	Test Conditions / Notes	Min.	Nominal	Max.	Units
AC Input Voltage	PS starts and operates at 90 V _{AC} at all load conditions	90	100-240	264	V _{AC}
DC Input Voltage		170	-	270	V _{DC}
Input Frequency		47	50/60	440	Hz
Input Current	RMS at 180 V _{AC} , maximum load RMS at 90 V _{AC} , maximum load	-	-	2.5 5	A
Inrush Current (peak)	265 V _{AC} , full load, cold start.	-	-	20	A
Fusing	2X Time Lag 6.3 A, 250 V on L and N	-	-	6.3	A
Efficiency	230 V _{AC} , From 50% to full load At 20% full load At 115 V _{AC} , 20% rated load At 100% load	-	94 90 90 92	- - - -	%
Input Power Consumption	Power on, 115-230 V _{RMS} , no load Stand by, 115-230 V _{RMS} , no load	-	1 0.4	1.5 0.5	W
Power Factor	At full rated load, 115 V _{AC} 60 Hz and 230 V _{AC} 50 Hz input voltages	0.95	-	-	-
Harmonic Current Fluctuations and Flicker	Complies with EN-61000-3-2 Class C at 230 V _{AC} 50 Hz, >50 W load. Complies with EN-61000-3-3 at nominal voltages and full load.				
Leakage Current	Normal conditions, 240 V _{RMS} , 60 Hz.	-	-	300	µA

Output Specifications

Specification	Test Conditions / Notes	Min.	Nom.	Max.	Units
V1 Output Voltage	12 V _{DC} 24 V _{DC} 36 V _{DC} 48 V _{DC} ±0.5 % set point accuracy on all outputs	-	12 24 36 48	-	V
V1 Output Power Rating	All models, convection cooling All models, conduction cooling / heat sink All models, peak power (≤ 10 s)	-	-	350 400 440	W
V2 Output Voltage	All versions. Load on V2: from 5 to 1000 mA Load on V1: from 0.1 to 16.7 A	11.25	12.5	13.75	V
V2 Output Current	All models, convection/forced air cooling	-	-	1	A
5V _{SB} Output Voltage	All models (3% set point accuracy)	-	5	-	V
5V _{SB} Output Current	All models, convection cooling All models, conduction cooling / heat sink	-	-	1.5 2	A
V1 Voltage Adjustment Range		±5	-	-	%V1
V1 Load-Line-Cross Regulation	V _{AC} : 90 – 264 V _{RMS} V1 Load: 0 – 33.3 A (12 V _{DC}) 0 – 16.7 A (24 V _{DC}) 0 – 11.1 A (36 V _{DC}) 0 – 8.3 A (48 V _{DC}) V2 Load: 0 – 1 A 5 V_{SB} Load: 0 – 2 A	-	-	±2	%V1
5V _{SB} Load-Line-Cross regulation	V _{AC} : 90 – 264 V _{RMS} V1 Load: 0 – 33.3 A (12 V _{DC}) 0 – 16.7 A (24 V _{DC}) 0 – 11.1 A (36 V _{DC}) 0 – 8.3 A (48 V _{DC}) V2 Load: 0 – 1 A 5 V_{SB} Load: 0 – 2 A	-	-	±5	%5V _{SB}
V1 Line Regulation	V _{AC} : 90 – 264 V _{RMS}	-	-	±0.1	%V1
Transient Response (Voltage Deviation) V1, 5V _{SB}	25 % load changes at 1 A/μs 12 V _{DC} at 2200 μF Load / I _{OUT} > 0.5 A 24 V _{DC} at 1000 μF Load / I _{OUT} > 0.5 A 36 V _{DC} at 820 μF Load / I _{OUT} > 0.5 A 48 V _{DC} at 560 μF Load / I _{OUT} > 0.5 A 5 V _{SB} at 560 μF Load / I _{OUT} > 0.1 A	-	-	±5	%V1 %5V _{SB}
V1 Ripple & Noise	All models, Peak-to-peak, 20 MHz BW. 100 nF ceramic and 10μF tantalum to the load.	-	-	1	%V1
Start-up Rise Time	90 < V _{IN} < 264, any load conditions.	5	-	85	ms
Start-up Delay	V1 in regulation after PS_ON is asserted V1 in regulation after AC is applied 5 V _{SB} in regulation after AC is applied	-	-	200 750 500	ms
Turn-on Overshoot	At 500 mA output current, V1 in regulation within 50 ms.	-	10 10 10	-	%V1 %V2 %V _{SB}
Hold-up Time	At nominal V _{IN} , 400 W, for all outputs At nominal V _{IN} , 365 W, for all outputs At nominal V _{IN} , 200 W, for all outputs	-	16 20 35	-	ms
Minimum Load (*)	All models; V1, V2 and 5V _{SB}	0	-	-	A
Maximum Load Capacitance	At nominal V _{IN} , 25 °C ambient 12 V _{DC} 24 V _{DC} 36 V _{DC} 48 V _{DC}	-	-	33.000 16.000 10.000 7.000	μF
Temperature Drift		-1.2	-	+1.2	mV/°C

(*) when the load on the main output is less than 100 mA, V2 output voltage might regulate below its minimum value. Contact Inission Power for details.

Power De-rating Curves

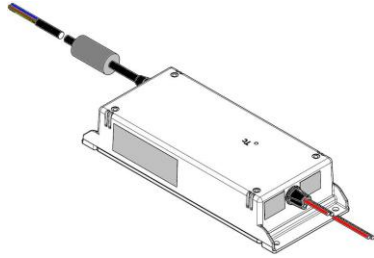

Sealed Box without Heatsink
DDP400-USxx-SC

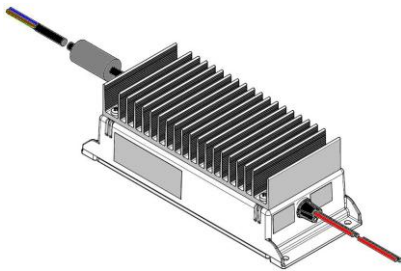
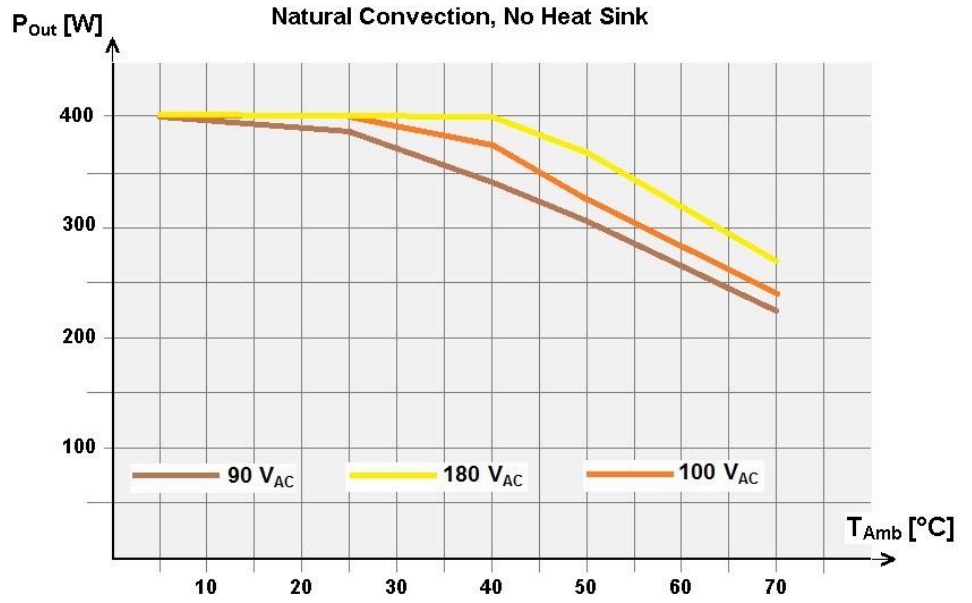

Sealed Box with Heatsink
DDP400-USxx-SC + DDP-HS

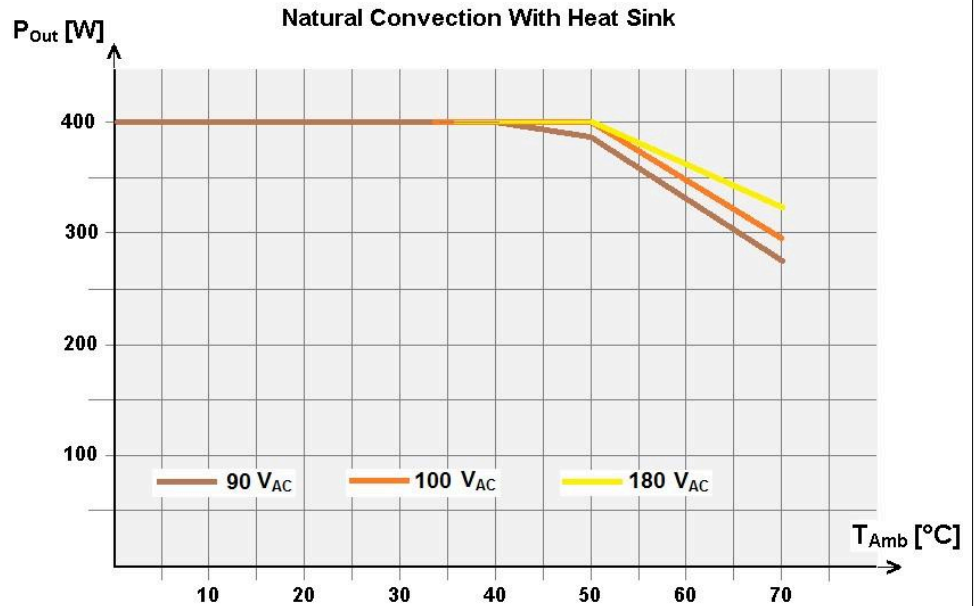

Signals / Controls and Timing

Signal	Notes	Min	Typ	Max	Unit
PS_ON	Active low, +5 V TTL signal compatible. Input low voltage	0	-	2.0	V
	Input high voltage ($I_{IN} = 200 \mu A$)	3.0	-	-	V
	V1 and V2 disabled when PS_ON is open				
	5 V _{SB} not affected by PS_ON				
	V1 and V2 enabled with PS_ON connected to RTN				
P_OK	+5 V TTL compatible				
	Logic level low (<10 mA sinking)	-	-	0.7	V
	Logic level high (100 μA sourcing)	2.4	-	5	V
	Low to high time after V1 in regulation	0.05	-	0.1	S
	Power down warning time	1	-	-	Ms
5 V_{SB} output	Active and in regulation after a $90 < V_{AC} < 264$ is applied	-	-	200	Ms
	5 V _{SB} not affected by PS_ON				

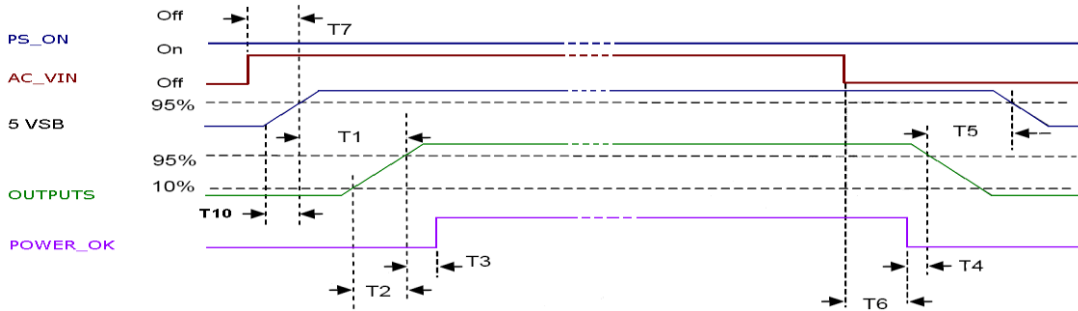

Above waveforms are expected with AC Input ON/OFF:

Standby on - Main outputs on	$50 \text{ ms} \leq T1 \leq 250 \text{ ms}$
Main output Rise Time	$5 \text{ ms} \leq T2 \leq 110 \text{ ms}$
5 V _{SB} Rise Time	$4 \text{ ms} \leq T10 \leq 20 \text{ ms}$
Main outputs On – P_OK delay	$25 \text{ ms} \leq T3 \leq 100 \text{ ms}$
Power down warning ¹	$T4 \geq 1 \text{ ms}$
Main Output off – Standby off ²	$T5 \geq 1.2 \text{ s}$
Hold-up time (AC off – P_OK low)	$T6 \geq 15 \text{ ms} (115/ 230 V_{AC})$
AC_ON - Standby turn on time	$T7 \leq 500 \text{ ms}$

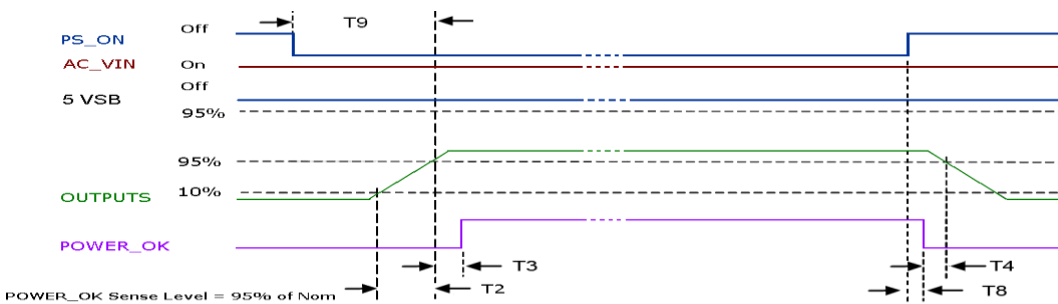

Above waveforms are expected with AC Input ON/OFF:

Main output Rise Time	$5 \text{ ms} \leq T2 \leq 110 \text{ ms}$
Main outputs On – P_OK delay	$25 \text{ ms} \leq T3 \leq 100 \text{ ms}$
Power down warning ¹	$1 \text{ ms} \leq T4 \leq 5 \text{ ms}$
PS_ON - Main Output (off) Timing	$T8 \leq 1 \text{ ms}$
PS_ON - Main Output (on) Timing	$T9 \leq 200 \text{ ms}$

¹ T4 parameter measurement setup will assume at least 10 % of the maximum load on each output.

² T5 parameter measurement setup will assume 50 % of the maximum load on 5 V_{SB}.

Protection Features

Specification	Test Conditions / Notes	Min.	Nominal	Max.	Units
Input Under Voltage	Auto-recovering, hiccup mode.	60	75	-	V _{AC}
Input Fuse	2X Time Lag 6.3 A, 250 V on L and N	-	-	6.3	A
Over Current	At nominal input voltages. V1: Hiccup mode, auto-recovering. V2: PTC limiting, auto-recovering. 5 V _{SB} : Hiccup mode, auto-recovering.	110	-	155	%I _{MAX}
Short Circuit	At nominal input voltages. V1: Hiccup mode, auto-recovering. V2: PTC limiting, auto-recovering. 5 V _{SB} : Hiccup mode, auto-recovering.	-	-	-	
Over Voltage	12 V _{DC} 24 V _{DC} 36 V _{DC} 48 V _{DC} 5 V _{SB} Shut down, latch-off.	110	-	136	%V _{NOM}
Over Temperature (on primary stage)	Shut down, latch off.	-	-	-	
Over Temperature (on secondary side)	Hiccup mode, auto-recovering.	-	-	-	
Isolation Primary to Secondary	Reinforced (2x MoPP)	5660 4000	- -	- -	V _{DC} V _{AC}
Isolation Input to Earth	Basic (1x MoPP)	1500			V _{AC}
Isolation V1 to V2	Functional	100	-	-	V _{DC}
Isolation Output to Earth	Basic (1x MoPP)	1500	-	-	V _{AC}

Environmental Specifications

Specification	Test Conditions / Notes	Min	Nominal	Max	Units
Operating Temperature Range	PS starts up at -30 °C See graphs above for output power de-rating against T _{Amb} and V _{In} .	-20	-	70	°C
Storage Temperature Range		-40	-	85	°C
Humidity	RH, Non-condensing Operating Non-operating	-	-	90 95	% %
Operating Altitude		-	-	4000	m
Shock	EN 60068-2-27 Operating: Half sine, 30 g, 18 ms, 3 axes, 6x each (3 positive and 3 negative). Non-Operating: Half sine, 50 g, 11 ms, 3 axes, 6x each (3 positive and 3 negative).				
Vibration	EN 60068-2-64 Operating: Sine, 10 – 500 Hz, 1 g, 3 axes, 1 oct/min., 60 min. Random, 5 – 500 Hz, 0.02 g ² /Hz, 1 g _{RMS} , 3 axes, 30 min. Non-Operating: 5 – 500 Hz, 2.46 g _{RMS} (0.0122 g ² /Hz), 3 axes, 30 min.				
MTBF	Full Load, 120 V _{AC} , 50 °C ambient 70 % Duty cycle, Telcordia Issue 1	400.00.00	-	-	Hours
Useful Life	Low line range, 200 W, 40 °C ambient, natural convection.	-	4	-	Years
Cooling	Convection with or without heat sink and conduction providing an adequate thermal path between the unit and the external environment. Case hot spot temperature, T _c , should not exceed 90 °C in any working condition.				

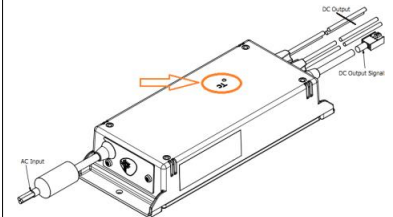

Electromagnetic Compatibility (EMC) – Emissions

Phenomenon	Conditions / Notes	Standard	Equipment/Performance Class
Conducted	115 V _{RMS} , 230 V _{RMS} . Maximum load. 4 dB minimum margin	EN 55032 (ITE) EN 55011 (ISM) EN 60601-1-2 (Medical)	B
Radiated	At 10 m distance	EN 55032 (ITE) EN 55011 (ISM) EN 60601-1-2 (Medical)	B
Line Voltage Fluctuation and Flicker	At 20%, 50% and 100% maximum load. Nominal input voltages.	EN 61000-3-3	
Harmonic Current Emission	Nominal input voltages. Output load > 50 W.	EN 61000-3-2	C

Electromagnetic Compatibility (EMC) – Immunity

Phenomenon	Conditions / Notes	Standard	Test Level	Performance criteria
	Reference standard for the medical version Reference standards for ITE	EN 60601-1-2, 4th edition EN 55024		
ESD	15 kV air discharge, 8 kV contact, at any point of the system.	EN 61000-4-2	4	A
Radiated Field	3 V/m, 80-1000 MHz, 1 KHz/2 Hz 80% AM. Dwell time is 3 sec for 2 Hz modulation Dwell time is 1 sec for 1KHz modulation	EN 61000-4-3	3	A
Electric Fast Transient	±2 kV on AC power port for 1 minute; ±1 kV on signal/control lines	EN 61000-4-4	3	A
Surge	± 2kV line to line; ± 4 KV line to earth; on AC power port; ±0.5 kV for outdoor cables	EN 61000-4-5	3	A B
Conducted RF Immunity	3 V _{RMS} , 0,15-80 MHz, 1 KHz/2 Hz 80% AM	EN 61000-4-6	3	A
Dips and Interruptions	Dip to 30% for 5 cycle (10 ms) Dip to 40% for 5 cycles (100 ms) Dip to 70% for 25 cycles (500 ms) Drop-out to 5% for 10 ms Interrupts > 95% for 5 s	EN61000-4-11 EN61000-4-11 EN61000-4-11 EN61000-4-11 EN61000-4-11		A B B B B

Safety Agencies Approvals

Certification Body	Safety Standards and file numbers	Category
CSA/UL	CSA C22.2 No. 60950-1, UL 60950-1 and UL 62368-1 CSA C22.2 No.601.1, ANSI/AAMI ES60601-1 3rd edition	Audio Video and Information Technology Equipment Medical
IEC IECEE CB Certification	IEC/EN 60950-1 and IEC/EN 62368-1 IEC/EN 60601-1 3rd edition	Audio Video and Information Technology Equipment Medical
CE	Low Voltage Directive (LDV) 2006/95/EC Low Voltage Directive (LDV) 2007/47/EC MDD	Audio Video and Information Technology Equipment Medical

Outline Drawing and Connections

OVERALL DIMENSIONS: 83 x 212 x 42 mm (3.27 x 8.34 x 1.65 in) | 83 x 212 x 70.13 mm (3.27 x 8.34 x 2.76 in) with heatsink
WEIGHT: 1300 g (2.87 lb) | 1665 g (3.67 lb) with heatsink

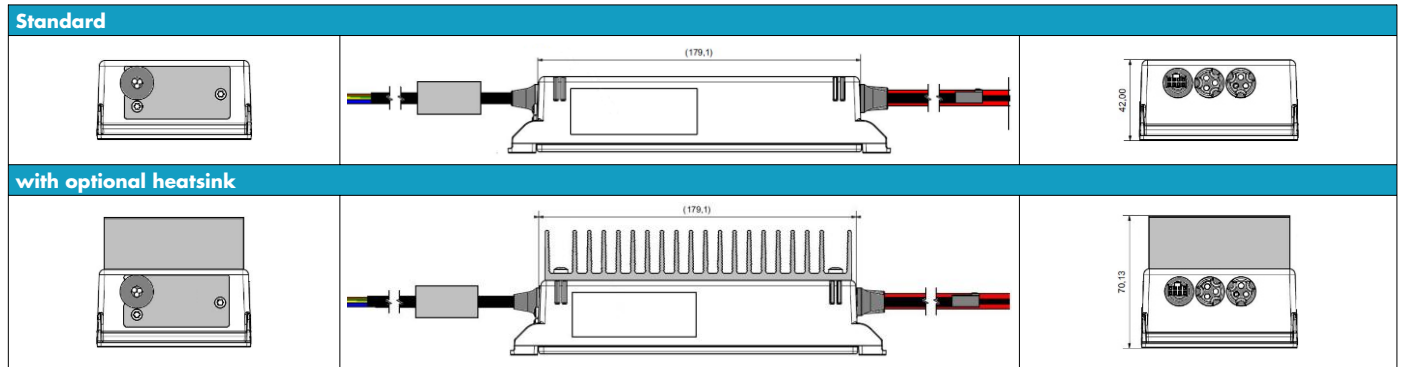
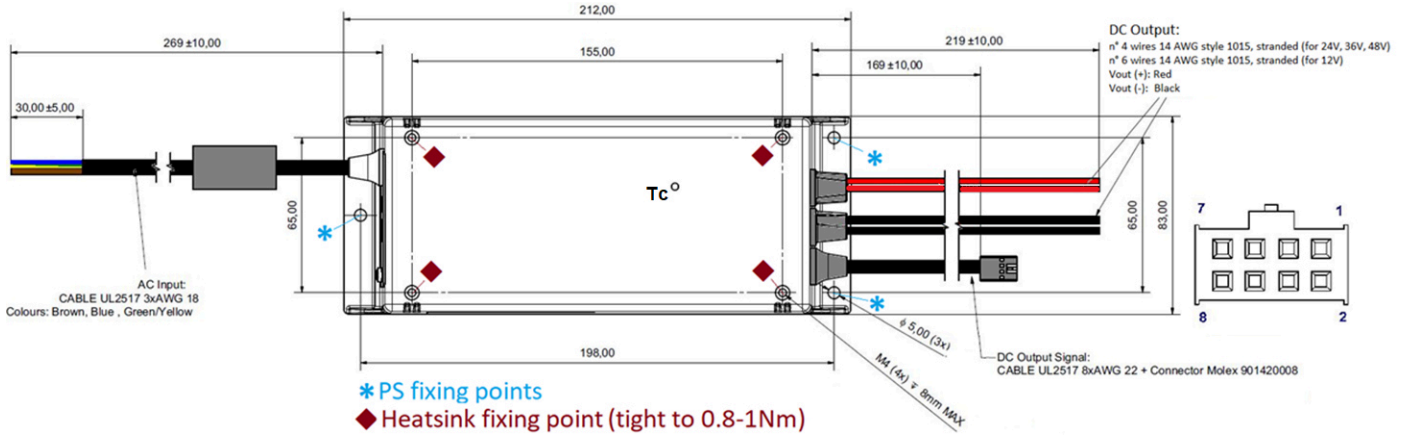

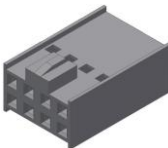
Connections	Wires Gauge and Length	Assignment	Colour/Pin
AC Input	3x 18AWG, black external insulation, 300V, 105°C, UL2517 cord, 310 ± 10 mm extension from grommet.	Live (L)	Brown
		Neutral (N)	Blue
		Protective Earth (PE)	Green Yellow
DC Output	12 V_{DC} version: 6x 14AWG, Style 1015, 600V, 105°C, 260±10 mm 24, 36, 48 V_{DC} versions: 4x 14AWG, Style 1015, 600V, 105°C, 260±10 mm	3x (2x) +V1 Output (+V1)	Red
		3x (2x) V1 Return (RTN)	Black
Auxiliary Voltages Control Signals  Wires: 8x 22AWG, black external insulation, 300V, 105°C, UL2517 cord, 220 ± 10 mm extension from grommet to connector. Housed by Connector: Molex 90142-0008 Terminals: Molex 90119-0109 (Tin plating) Mates with Molex 90130-1108 or equivalent Terminals: Tin plating termination		+5 V Stand-by Output (+5VSB)	Red / 1
		Output Power Good (P_OK)	Green / 2
		- Fan Voltage (-V2)	Brown / 3
		Remote On/Off (PS_ON)	Grey / 4
		+ Terminal Remote Sense (+RS)	Yellow / 5
		Stand-by/Signals Return (RTN)	Blue / 6
		+ Fan Voltage (+V2)	White / 7
		Stand-by/Signals Return (RTN)	Black / 8

Specifications appearing in Inission's catalogues and brochures as well as any oral statements are not binding. All descriptions, drawings and other particulars (including dimensions, materials and performance data) given by Inission are as accurate as possible but, being given for general information, and are not binding on Inission. Inission makes thus no representation or warranty as to the accuracy of such material. We assume no liability other than as agreed in the terms of the individual contracts and we reserve the right to make technical modifications in the course of our product development. Our product information solely describes our goods and

services and is in no way to be construed or interpreted as a quality or condition guarantee. The aforesaid shall not relieve the customer of its obligation to verify the suitability of our Products for the use or application intended by the purchaser. Customers are responsible for their products and applications. Inission assumes no liability from the use of its products outside of specifications. No license is granted to any intellectual property rights by this document.