

## MAIN FEATURES

- Nominal input voltage: 220-240/277/347/400 V<sub>AC</sub>
- Insulation Class I
- 3 independent and individually controllable output channels
- Non-isolated outputs
- Max output power 684 W per output channel
- Output current range, DMX programmable: 700-1400 mA (per channel)
- Output voltage range 300 – 565 V<sub>DC</sub> (per output channel)
- IEEE 1789 flicker recommended practice compliant
- Remote installation capability up to 200 m
- DMX-RDM control up to 33 FPS
- Smooth dimming down to 12.5 mA (Dim-To-Off)
- No afterglow when Dim-to-Off asserted
- Surge level 10 kV for both common mode and differential mode
- Certification CE, UKCA and UL ENEC; full design conformity to China, Australia and New Zealand safety standards
- Adaptive thermal protection for LED module connected to ch. #2
- Lifetime: 50.000 hours at maximum load, 45°C ambient T
- Short circuit, overpower, over voltage and no-load protections
- Remote firmware update through DMX-RDM interface
- IP66, IK08, C5-M rated enclosure
- Compatible with Emergency Lighting (EL) requirements



**IP66 – IEC 60529**  
**IK08 – EN 62262**  
**C5-M – ISO 12944**



## DESCRIPTION

This datasheet details the electrical, mechanical and environmental specifications of a Class I non-insulated, 2052 W, 3 (three) output constant current channels, DMX-RDM programmable, LED driver. Its IP66 enclosure, including a built-in junction box, and high AC port surge immunity, make it suitable for outdoor and harsh environment applications. Its output currents characteristic makes it suitable for HD Slow-Mo TV broadcasting applications.

The DLD2052 LED driver has been specifically conceived to supply high quality and programmable constant current to high end professional LED modules capable of very high luminous flux (> 82000 lm) for sport venues lighting, large area lighting, horticulture, tunnel and high-mast lighting in general.

It comes ENEC certified, and UL listed, according to latest IEC/EN 61347-2-13, IEC/EN 61347-1, IEC/EN 62384 and ANSI / UL8750, CSA C22.2 No.250 safety standards. It carries CE and UKCA marks and its design is fully complying with CCC and RCM safety requirements.

The DLD2052 Series is compatible to emergency lighting – EL – operating conditions.

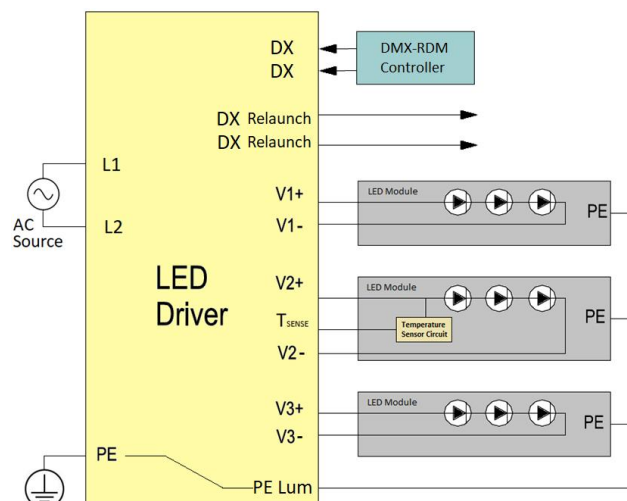

### MODEL CODING AND OUTPUT RATINGS

Model Ordering Code	Dimming	Output Channels	Pout Max [W]	V <sub>OUT</sub> Min [V <sub>DC</sub> ]	V <sub>OUT</sub> Max [V <sub>DC</sub> ]	I <sub>OUT</sub> Programmable Settings [mA]				
DLD2052-H120-DX RHPS579B-A-x	DMX-RDM	3	2052	300	565	700	850	1050	1200 <sup>1</sup>	1400

<sup>1</sup> -A: factory default setting output current (1200 mA). -x: product developing/engineering level

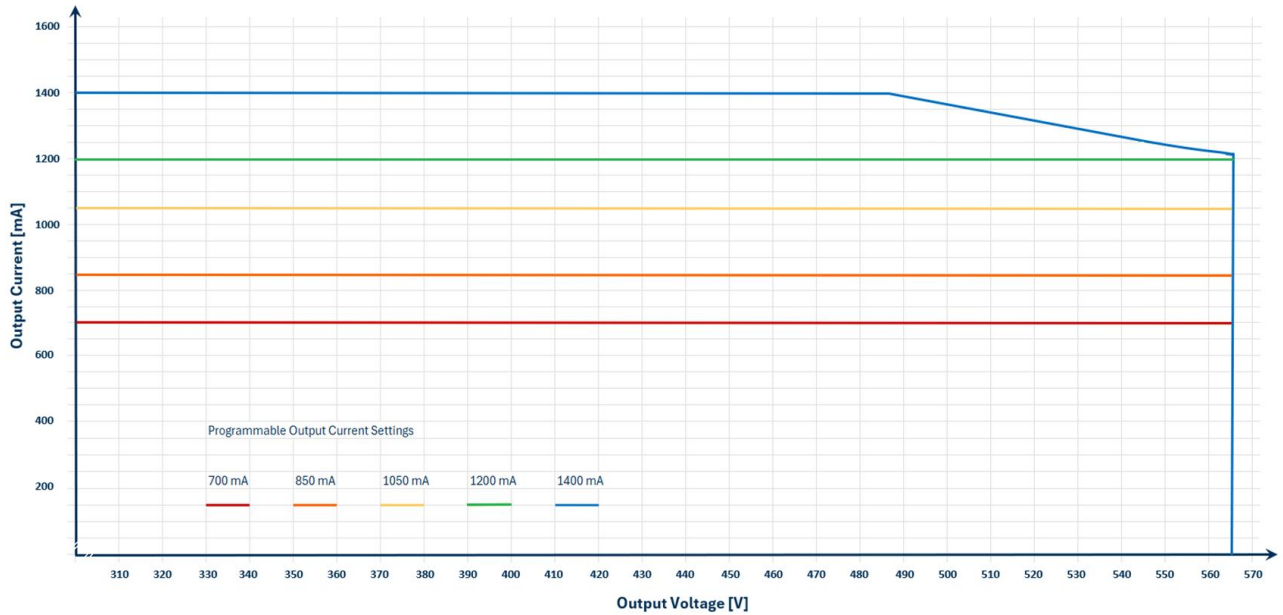

### INPUT SPECIFICATION

Specification	Test Conditions / Notes	Min	Nom	Max	Units
<b>AC Input Voltage</b>	220-240/277/347/400 V <sub>AC</sub> Device starts and operates at 190 V <sub>AC</sub> at all load conditions	198	220-400	440	V <sub>AC</sub>
<b>Input Frequency</b>		47	50/60	63	Hz
<b>Standby Power</b>	At 220-240 V <sub>AC</sub> At 277 V <sub>AC</sub> At 400 V <sub>AC</sub>	-	0.38 0.45 0.74	0.5 0.5 1	W
<b>Efficiency</b>	220-240 V <sub>AC</sub> Full load (1400 mA, 485 V) 400 V <sub>AC</sub> Full load (1400 mA, 485 V)	95.5 96	96 97	- -	%
<b>Efficiency</b>	220-240 V <sub>AC</sub> 87% load (1050 mA, 565 V) 400 V <sub>AC</sub> 87% load (1050 mA, 565 V) 220-240 V <sub>AC</sub> 58% load (700 mA, 565 V) 400 V <sub>AC</sub> 58% load (700 mA, 565 V)	95 96 95 96	95.5 96.5 95.5 96.5	- - - -	%
<b>Input Current</b>	198 V <sub>AC</sub> Full load 220 V <sub>AC</sub> Full load 400 V <sub>AC</sub> Full load	- - -	- - -	11.0 10.0 5.0	A
<b>Leakage Current</b>	230 V <sub>AC</sub> , 50/60 Hz, IEC60598-1, normal conditions 400 V <sub>AC</sub> , 50/60 Hz, IEC60598-1, normal conditions	- -	0.6 0.6	0.7 0.7	mA
<b>Power Factor</b>	220-240 V <sub>AC</sub> Full load (1400 mA, 485 V) 220-240 V <sub>AC</sub> Half load (700 mA, 485 V) 400 V <sub>AC</sub> Full load (1400 mA, 485 V) 400 V <sub>AC</sub> Half load (700 mA, 485 V)	0.99 0.98 0.98 0.97	- - - -	- - - -	
<b>THD</b>	230 V <sub>AC</sub> Full load (1400 mA, 485 V) 230 V <sub>AC</sub> Half load (700 mA, 485 V) 400 V <sub>AC</sub> Full load (1400 mA, 485 V) 400 V <sub>AC</sub> Half load (700 mA, 485 V)	- - - -	- - - -	3 9 10 11	%
<b>Inrush Current (peak)</b>	240 V <sub>AC</sub> Half Value Time: 6 ms 400 V <sub>AC</sub> Half Value Time: 5.4 ms	- -	- -	16 22	A
<b>Harmonic Current</b>	Complies with EN-61000-3-2, Class C, load ≥30%				
<b>Hot Restrike</b>	Hot restrike in less than 1 s preventing the triggering of a circuit breaker "C-Type 16A MCB" connected with 1 Driver				

**Note:** the specified load conditions reported in the "Test Conditions / Notes" column, are simultaneously applied to all output channels.

**OUTPUT SPECIFICATIONS**

Specification	Test Conditions / Notes	Min	Nom	Max	Units
<b>Output Channels</b>	3 independent output channels				
<b>Total Output Power</b>		-	-	2052	W
<b>Output Power Rating</b>	Per output channel	-	-	684	W
<b>Output Voltage</b>	Per output channel	300	-	565	V <sub>DC</sub>
<b>Output Voltage to Earth</b>	Per output channel			600	V <sub>RMS</sub>
<b>Output Current</b>	Programmable via DMX-RDM in 5 steps: 700 / 850 / 1050 / 1200 (factory set) / 1400 Fine tuning capability via DMX	700	-	1400	mA
<b>Amplitude Dimming</b>		150	-	1400	mA
<b>PWM Dimming</b>	1.25 kHz	12.5	-	150	mA
<b>High Frequency Ripple Current</b>	At 220, 277, 400 V <sub>AC</sub> nominal input voltages High frequency: >15 kHz, I <sub>Peak-to-Peak</sub> /I <sub>AVG</sub> at 1400 mA, 485 V, full load	-	-	25	%
<b>Low Frequency Ripple Current</b>	At 220, 277, 400 V <sub>AC</sub> nominal input voltages Low frequency: <1 kHz, I <sub>Peak-to-Peak</sub> /I <sub>AVG</sub> at 1400 mA, 485 V, full load	-	-	2	%
<b>Flicker for viewers</b>	IEEE 1789 Flicker Recommended Practice Compliant from 100% (1400 mA) to 0.89% (12.5 mA) I <sub>OUT</sub>				
<b>Flicker for HD TV broadcasting</b>	Flicker free up to 1000 FPS from 1400 to 400 mA I <sub>OUT</sub>				
<b>Glimmering</b>	No glimmering after 0.5 s stand-by mode is asserted				
<b>Current Set Accuracy</b>	Relevant to all the 5 nominal output current settings	-	±3	-	%I <sub>OUT</sub>
<b>Turn-on Time</b>	Compliant with clause 9.13 of IEC 62386-102:2014 220 / 277 / 400 V <sub>AC</sub> ; 565 / 485 / 300 V <sub>DC</sub> 700 / 850 / 1050 / 1200 / 1400 mA I <sub>OUT</sub>	-	0.7	1	s
<b>Max Remote distance</b>	Max distance between the LED driver and each LED module connected with an appropriate cable section to ensure a total voltage drop < 5 V on each channel. The total V <sub>F</sub> shall not exceed the max V <sub>OUT</sub> , and total P <sub>OUT</sub> shall not exceed its rated value			200	m

## PROTECTION FEATURES

Specification	Test Conditions / Notes	Min	Nom	Max	Units
<b>AC input Undervoltage</b>	The Driver switches Off (all channels shutdown) and auto recovers when V <sub>AC</sub> input reach minimum 190 V	-		190	
<b>AC input Overvoltage</b>	The driver switches Off (all channels shutdown) and auto recovers when V <sub>AC</sub> input falls within 450 V	460	-	465	
<b>Output Over Voltage</b>	The faulty channel shuts down and restarts approximately every 5 s  External surge on output - Voltage spike limiting / suppression Common mode (LED <sup>+</sup> /LED <sup>-</sup> -to-PE) Differential mode (LED <sup>+</sup> to LED <sup>-</sup> )	580	-	600	kV
<b>Output Under Voltage</b>	The faulty channel shuts down and restarts approximately every 5 s A permanent undervoltage condition is indicated on the front panel Status LED.	200	-	300	V
<b>Output Short-Circuit (*)</b>	No damage, no components overstress Short applied à AC asserted: channel shuts down, restart attempts every 5-6 s. AC asserted à Short applied: channel shuts down. AC cycled Off-On to recover operations. A permanent short-circuit condition is indicated on driver front panel Status LED				
<b>Overpower (*)</b>	In case the output power in a channel exceeds the rated value, its current will be reduced so to bring it back to the limit in a fold back mode. The driver recovers to originally programmed current after overpower condition is cleared. Max output power w/o derating			690	W
<b>Internal Over-Temperature vs T<sub>AMB</sub></b>	The LED Driver checks the internal temperature in each channel every 60 seconds. If an over temperature is detected, the output current is gradually reduced (3% I <sub>SET</sub> every 60 s). In any condition the output current will not decrease below 20% of the set current. An internal over temperature condition is indicated on the front panel status LED.	105	-	107	°C
<b>No Load V<sub>OUT</sub> Transient (peak)</b>	The open-load or no-load condition is regarded as faulty which makes the relevant channel shut down. The driver will then attempt to restart the channel/s approximately every 7-7.5 s. No damage, no components overstress. No load condition is indicated on front panel Status LED.	-	-	650 600	V <sub>PEAK</sub> V <sub>RMS</sub>
<b>External (LED Module) Over Temperature</b>	External thermal protection is set at 110 °C. See "NTC Dimming" chapter herein after. An external over temperature condition is indicated on the front panel status LED.	110	-	130	°C
<b>Isolation</b>	Class I (with PE)				

(\*) – In case of a faulty or broken driver the channel output current cannot be limited

## OPERATING STATUS AND DIAGNOSTIC LED SIGNALLING

The driver is equipped with an LED indicator which, in addition to signalling its normal operation, also signals any abnormal operating condition through a series of coded luminous flashes.

Operating Status / Abnormal conditions	Priority <sup>(3)</sup>	Signalling Code
One or more active CCR <sup>(1)</sup> modules is not working		One 200 ms flash every 4 s
Firmware version of one or more CCR <sup>(1)</sup> module is not compatible with main control board firmware		Eight 200 ms flashes every 4 s
Short circuit on one or more active <sup>(2)</sup> outputs		Two 200 ms flashes every 4 s
One or more active <sup>(2)</sup> outputs disconnection from load		Three 200 ms flashes every 4 s
Overload on one or more active outputs		Four 200 ms flashes every 4 s
Undervoltage on one or more active outputs		Five 200 ms flashes every 4 s
Internal thermal derating intervention (output current reduction)		Six 200 ms flashes every 4 s
External thermal derating intervention (output current reduction)		Seven 200 ms flashes every 4 s
When the driver switched On, the LED lights steady green for 5 s, regardless of the status of the signals		
During normal operation the LED lights steady green		

<sup>(1)</sup> CCR module stands for Constant Current Regulator module (is the hardware that controls current output for a single output)

<sup>(2)</sup> "active" means enabled through drivers' configuration/control panel

<sup>(3)</sup> if more than one event worthy of signalling occurs, simultaneously, the LED signalling will refer exclusively to the event at higher priority

## INFORMATION ON ISOLATIONS

- The driver is a Class I electronic device offering a basic insulation to its metallic cover
- The DMX control terminals in some installations are considered FELV control terminals. DMX control circuitry is separated from primary / LED outputs circuits by a reinforced isolation barrier
- NTC control circuit is not separated from Primary / LED outputs circuits
- LED outputs circuits are not galvanically isolated from primary circuit. Maximum output operating voltage is 600 V to assure LED-to-PE Isolation
- LED outputs circuits are not separated from each other LED outputs circuits
- U-OUT = 600 V

	AC Input	+LED / -LED and NTC	DMX	PE / Housing	LUM PE
AC Input		None	Reinforced	Basic	Basic
+LED / -LED	No isolation		Reinforced	Basic	Basic
DMX	Reinforced	Reinforced		Reinforced	Reinforced
PE / Housing	Basic	Basic	Reinforced		
LUM PE	Basic	Basic	Reinforced		

## INRUSH CURRENT DATA

The maximum number of LED drivers connectable to a single MCB is reported in the following table for each nominal input voltage. Due to the different kinds of circuit breakers available on the market, this table is just for reference.

V <sub>IN</sub>	Inrush Current Data			# Drivers For Each Circuit Breaker											
	Nominal [V <sub>AC</sub> ]	I <sub>peak</sub> [A]	Half Value Time [μs]	Type B 16A	Type B 20A	Type B 25A	Type B 32A	Type C 16A	Type C 20A	Type C 25A	Type C 32A	Type D 16A	Type D 20A	Type D 25A	Type D 32A
230	16	6000		1	1	2	2	1	1	2	2	1	1	2	2
400	22	5400		2	2	3	5	2	3	3	5	2	3	4	5

## OUTPUT CONTROLS

DMX-RDM Dimming Control:

The driver provides a DMX\_RDM interface compliant with ANSI E1.11 (DMX 512), ANSI E1.20 and ANSI E1.37-1.

The 3 output channels will have the same current setting; it is possible to assign an individual DMX address to each output configuring them as independently dimmable.

Dimming range: 12.5 mA to 100% of the rated current.

Dimming Type: Constant Amplitude dimming from 100% rated current to 150 mA, PWM dimming from 150 mA to 12.5 mA at 1.25 kHz.

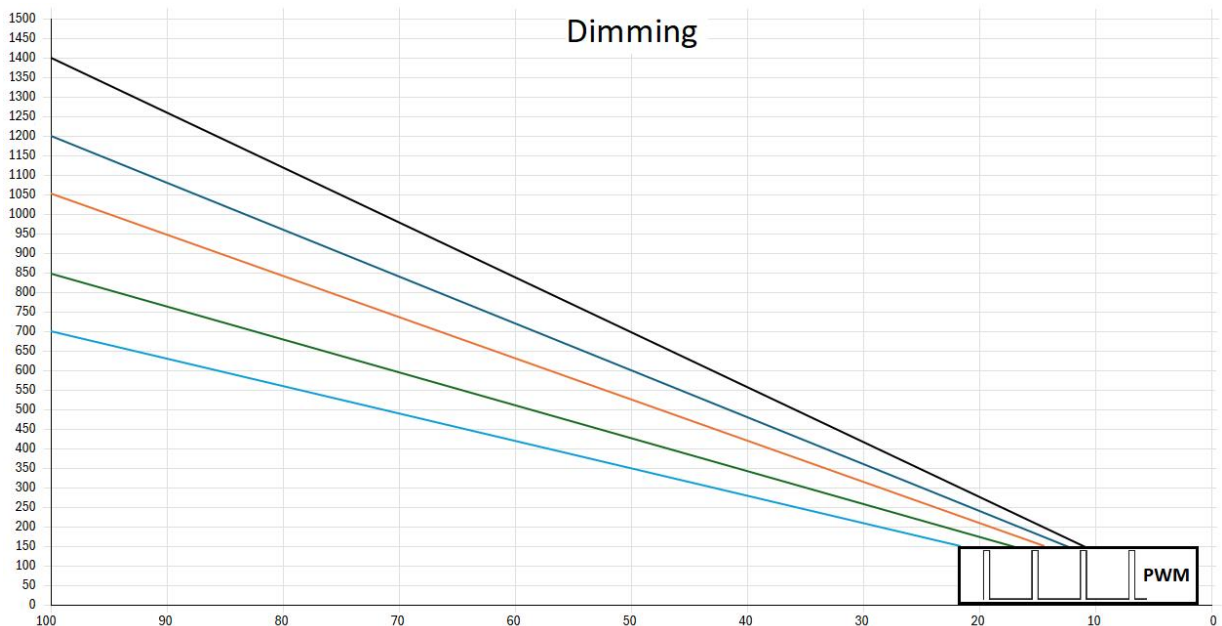

## OUTPUT CURRENT SETTINGS (THROUGH DMX-RDM)

The output currents indexes are set by the factory using a dedicated Manufacturer Specific PID (PW protected)

ENGINEERING CODE	ORDERING CODE	OUTPUT CURRENT	INDEX
RHPS579B-D	DLD2052-H070-DX	700	1
RHPS579B-C	DLD2052-H085-DX	850	2
RHPS579B-B	DLD2052-H105-DX	1050	3
<b>RHPS579B-A</b>	<b>DLD2052-H120-DX</b>	<b>1200 (*)</b>	4
RHPS579B-O	DLD2052-H140-DX	1400	5

(\*) factory pre-set current

## NTC DIMMING

The External LED module temperature can be read and controlled connecting the following circuit, using an NTC thermistor, to the LED driver.

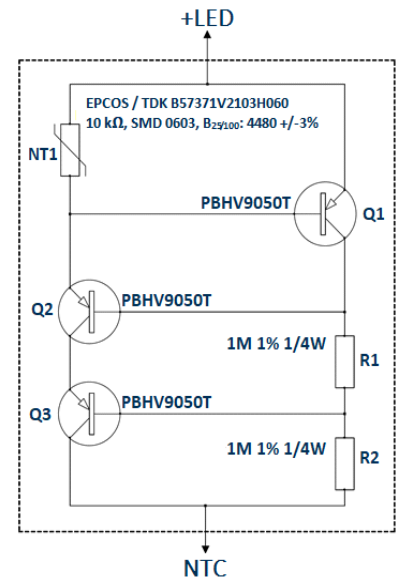
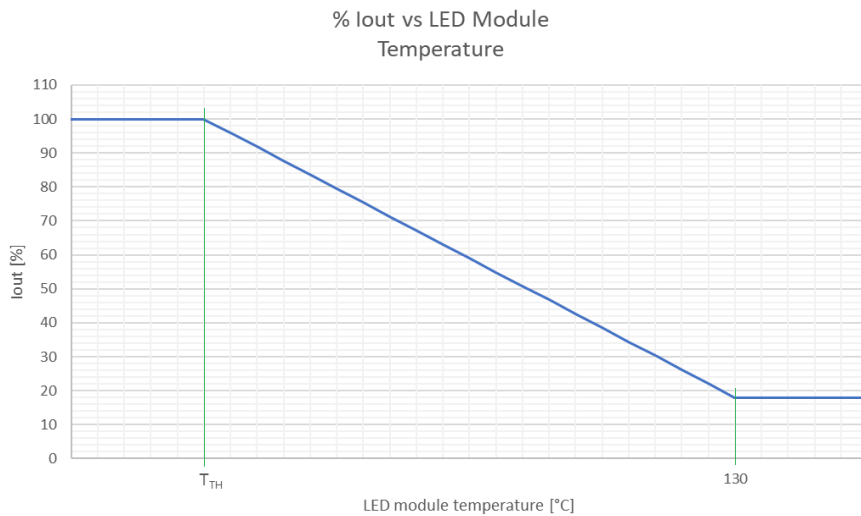

The thermal measurement is performed connecting NTC circuit from the pin LED+ and the NTC pin.

The NTC circuit must be placed on the LED assembly to monitor its temperature. When the temperature exceeds a predetermined threshold value ( $T_{TH}$ ), the output current provided to the module will automatically and gradually decrease to bring the temperature of the LED assembly back to safe value.

The NTC signal does access and is read by one single channel, which however replicates the same thermal protection dimming value identified to the other LED output channels.

The driver has been factory set considering a 110 °C NTC. It can be used other NTC ratings (90 ÷ 110 °C) upon LED driver setting (see User Manual for instruction).

*NOTE: The temperature measurement accuracy depends on the load condition.*

## MECHANICAL DETAILS

<b>Box:</b>	Die cast EN AC-43400 or EN AC-44300 Aluminium alloy
<b>Finishing:</b>	Powder coating, colour Traffic Gray A RAL 7042
<b>I/O Connections:</b>	Push-in connectors Input Connections: L1, L2, PE Control Connections: A, B, S; double connection for DMX-RDM daisy chain re-launch Output connections: (LED+, LED-) x 3 channels + PE LUM + NTC
<b>Signal LED</b>	Shows the LED driver state
<b>Ingress Protection:</b>	IP66 rated as per EN 60529 standard
<b>IK Code:</b>	IK08 rated as per EN 62262 standard
<b>Dimensions:</b>	500 x 150 x 120 mm (19.68 x 5.90 x 4.72 in)
<b>Mass:</b>	6.1 kg (13.45 lbs)
<b>Packaging:</b>	carton box 590 x 195 x H160 mm (23.22 x 7.67 x 6.29 in)

## OUTLINE DRAWING

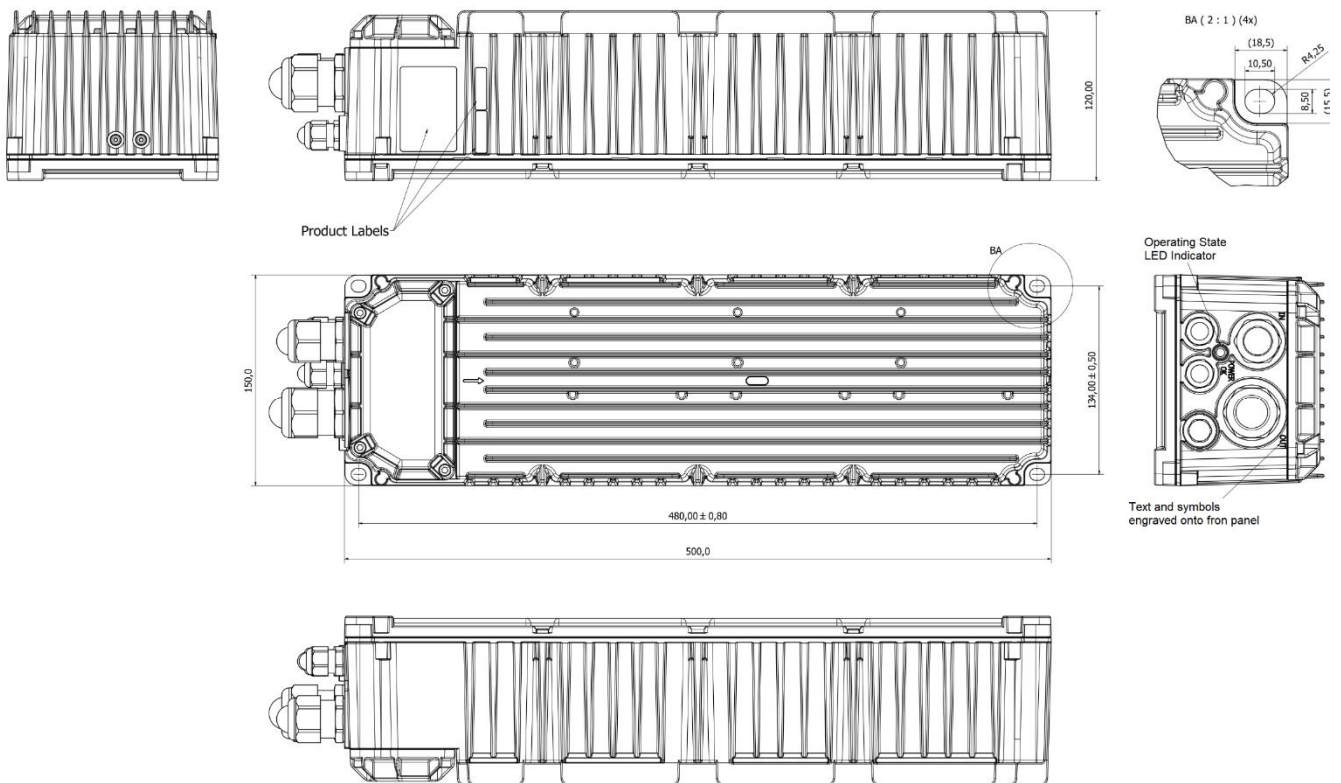

## INPUT / OUTPUT CONNECTIONS

All connections to and from the DLD2052-H120-DX LED drivers are made by means of mini feed-through terminal block.

	<p><b>Mains Section (AC Side)</b> Three input terminal blocks, for AC input, L1, L2 and PE connections (M25 Cable Gland). Total number of mains connection is composed of 3 positions.</p>
	<p><b>DMX Control Section (DMX Relaunch)</b> DMX_in, DMX_in, (M16 Cable Gland); DMX_rel, DMX_rel (M16 Cable Gland). Total number of Control connections is composed of 6 positions.</p>
	<p><b>Output Connections</b> PE LUM, NTC, LED1+, LED1-, LED2+, LED2-, LED3+, LED3- (M32 Cable Gland) Total number of Output connections is composed of 8 positions.</p>

**Connection method:**

Spring-cage connection, number of connections: 13, cross section: 0.8 - 4 mm<sup>2</sup>, AWG: 18-12.

(1.5-4 mm<sup>2</sup>, AWG: 15-12 for AC input, PE and +/- LEDs)

Mounting type: Direct mounting with flange

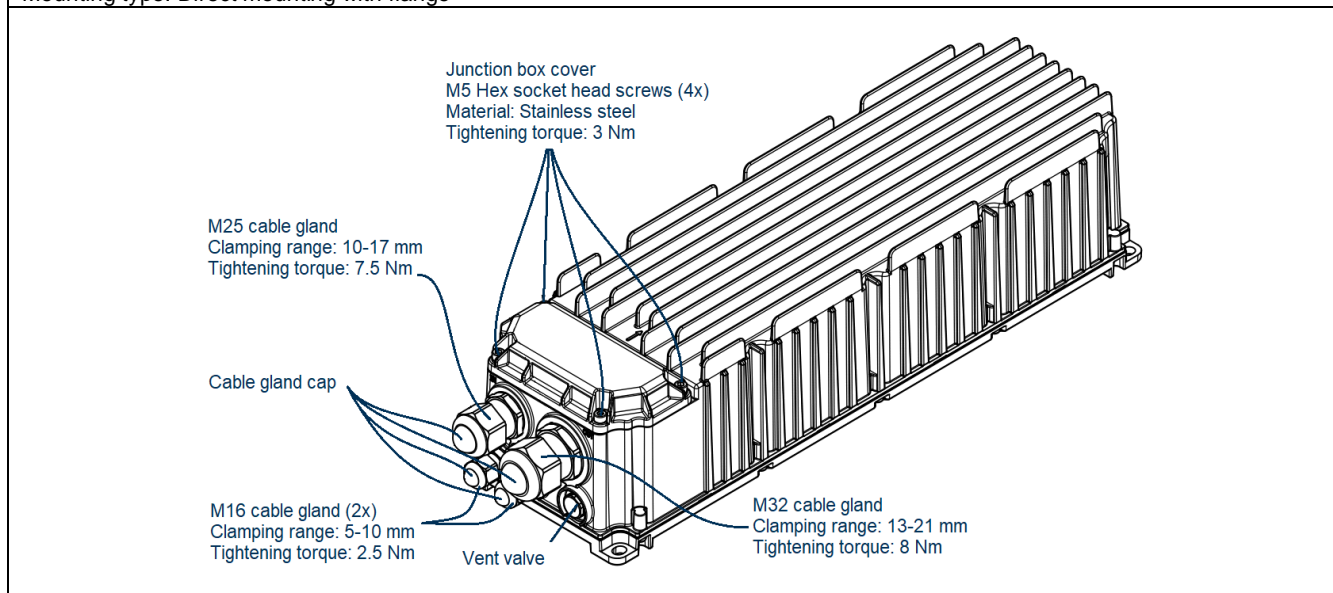

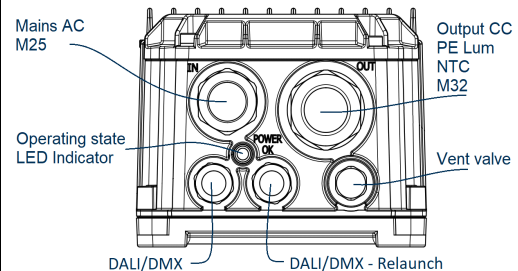

Connection	Torque [Nm]	Ø Min [mm]	Ø Max [mm]	Connector AWG	Section <sup>5</sup> [mm <sup>2</sup> ]	Front View
Mains Cable <b>M25</b>	7.5 (6 – 6.5) <sup>6</sup>	12 (7) <sup>6</sup>	17 (13) <sup>6</sup>	15 – 12	1.5 – 2.5	
DMX Cable <b>M16</b>	2.5	5	10	18 – 12	0.8 – 2.5	
Output Cable <b>M32</b>	8 (8) <sup>6</sup>	13 (8) <sup>6</sup>	21 (14) <sup>6</sup>	15 – 12	1.5 – 2.5	

<sup>5</sup> Up to 2.5 mm<sup>2</sup> for stranded conductor, up to 4 mm<sup>2</sup> for rigid conductor

<sup>6</sup> Reduced inner gaskets available as optional upon request to accommodate smaller cables diameters and ensure the right tightening. Relevant code for M25, (GPN17, 7-13 mm), for M32 (GPN19, 8-14 mm) (CEMBRE 2-Circuits seal Ø8 mm 36A3M322B). Use the right torque force based on the cable diameter and type (external insulating material).

**TERMINAL BLOCK CIRCUIT ASSIGNMENT**

TERMINAL BLOCK CIRCUIT ASSIGNMENT		
REF NUMBER	LABEL	DESCRIPTION
1	L1	AC LINE 1 INPUT
2	L2	AC LINE 2 INPUT
3		PROTECTIVE EARTH
4	A	DMX-RDM INPUT
5	A	DMX-RDM-RELAUNCH
6	B	DMX-RDM INPUT
7	B	DMX-RDM-RELAUNCH
8	S	DMX COMMON / SHIELD
9	S	DMX COMMON / SHIELD
10		PROTECTIVE EARTH FOR LED MODULE
11	NTC	THERMAL MEASURE INPUT
12	+1	LED1+ CONNECTION
13	-1	LED1- CONNECTION
14	+2	LED2+ CONNECTION
15	-2	LED2- CONNECTION
16	+3	LED3+ CONNECTION
17	-3	LED3- CONNECTION

**INSTALLATION NOTICE – TC AT MAX LOAD AND MAX TAMB**

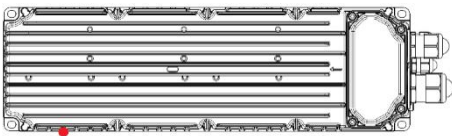
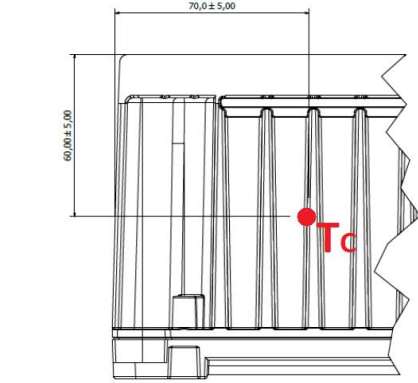
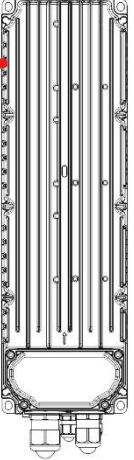
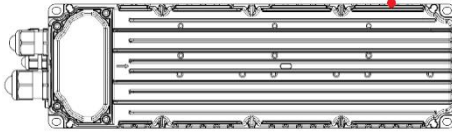
T <sub>c</sub> Reference at Max Ambient Temperature			
POSITION	SIDE (PARALLEL)	HORIZONTAL	VERTICAL
<b>MOUNTING</b>	 <b>JUNCTION BOX (RIGHT)</b>	 <b>T<sub>c</sub></b>	
	 <b>JUNCTION BOX (LEFT)</b>		
<b>220 / 240 VAC</b>	<b>76 °C (LEFT) / 75 °C (RIGHT)</b>	<b>70 °C</b>	<b>76 °C</b>
<b>400 VAC</b>	<b>68 °C (LEFT) / 67 °C (RIGHT)</b>	<b>63 °C</b>	<b>76 °C</b>
<b>MAX AMBIENT TEMPERATURE @2052W</b>	<b>45 °C</b>	<b>45 °C</b>	<b>45 °C</b>

**ENVIRONMENTAL SPECIFICATIONS**

Specification	Test Conditions / Notes	Min	Nom	Max	Units
<b>T<sub>c</sub> Temperature Range</b>	Case reference temperature without derating, please see Installation notice.	-40	-	80	°C
<b>Ambient Temperature Range</b>		-40	-	50	°C
<b>RH Operative Range</b>	Outdoor and harsh environment suitable for	5	-	100	%
<b>Storage Temperature</b>	Relative humidity 95% non-condensing	-40	-	85	°C
<b>Cooling</b>	Natural convection				
<b>Shock EN 60068-2-27</b>	Operating: Half sine 30 g/18 ms, 3 axes, 6x each (3 positive and 3 negative) Non-Operating: Half sine, 50 g/11 ms, 3 axes, 6x each (3 positive and 3 negative)				
<b>Random Vibration EN 60068-2-64</b>	Operating: 5-500 Hz, 1g <sub>RMS</sub> (0.02 g <sup>2</sup> /Hz), 3 axes, 30 min, random Non-Operating: 5-500 Hz, 2.46 g <sub>RMS</sub> (0.0122 g <sup>2</sup> /Hz), 3 axes, 30 min, random				
<b>Sinusoidal Vibration EN 60068-2-6</b>	Operating Sine, 10-500 Hz, 1 g, 3 axes, sweep 1 Oct/min., 60 min, 1 g - survival				
<b>MTBF</b>	Telcordia SR-332 Issue 2, Method 1, Case 3 25 °C ambient, max load, duty 50% 40 °C ambient, max load, duty 50%	-	1600000	-	hours
<b>Useful Life</b>	Maximum load (2052 W), 220-400 V <sub>AC</sub> nominal input voltage				
	<b>Control Gear Orientation</b>	<b>35 °C</b>	<b>40 °C</b>	<b>45 °C</b>	
	SIDE – Junction box left	96.097 h (10.97 years)	67.978 h (7.76 years)	48.092 h (5.49 years)	
	SIDE – Junction box right	103.543 h (11.82 years)	73.146 h (8.35 years)	51.772 h (5.91 years)	
	VERTICAL – Junction box bottom	91.279 h (10.42 years)	64.474 h (7.36 years)	45.640 h (5.21 years)	
	HORIZONTAL	107.573 h (12.28 years)	76.037 h (8.68 years)	53.786 h (6.14 years)	

**USEFUL LIFE PREDICTION BASED ON TYPICAL MISSION PROFILES. WARRANTY TERMS AND CONDITIONS**

Conditions																								
<p>a. Any scenario which it is expected a Useful Life (UL) longer than 5 (five) years for, shall prescribe an installation environment protected from water / pollutants ingress.</p> <p>b. Mission profiles are based on a statistical evaluation starting from LED driver MTBF and Useful Life estimations.</p> <p>c. Electrolytical capacitor reliability does anyway limit each scenario to 15 years.</p> <p>d. End of life here is intended as the time where 10% of drivers operating in the field have failed. C<sub>10</sub>: 90% reliability and 10 % unreliability.</p> <p>e. Enedo liability is defined as per warranty agreement that specifies terms/conditions of usage.</p> <p>f. The LED driver is covered by 5 years warranty term as a standard. 5 years warranty extension is an optional under specified conditions. Mission profile is only an indication of usage profiles compatible with relevant LED driver reliability parameters (MTBF, UL).</p> <p>g. 5 years warranty extension is applicable when driver is protected installed (outdoor into shelter / cabinet or indoor control room / technical room).</p> <p>h. The driver installed in a polluted or contaminated environment, swimming pool (Chlorine) and tunnel (sulphuric or nitric acid), shall be operated in a corrosion agents proof housing.</p> <p>i. The input and output cables should be routed and anchored to the luminaire fixture in such a way as to minimise any mechanical stress induced to plastic glands.</p> <p>j. Opening the driver enclosure (excluding junction box section) will void any warranty terms.</p>																								
Mission Profiles																								
<b>Mission Profile A</b>		<table border="1"> <tr> <td>MTBF (2000 W)</td> <td>duty</td> <td>0,5</td> </tr> <tr> <td>35</td> <td>735000</td> <td>50% duty</td> </tr> <tr> <td>35</td> <td>735000</td> <td>50%</td> </tr> <tr> <td>Time</td> <td>years</td> <td>hours</td> </tr> <tr> <td></td> <td>8,8</td> <td>77440</td> </tr> <tr> <td>Reliability</td> <td>90%</td> <td></td> </tr> <tr> <td>Unreliability</td> <td>10,0%</td> <td></td> </tr> </table>		MTBF (2000 W)	duty	0,5	35	735000	50% duty	35	735000	50%	Time	years	hours		8,8	77440	Reliability	90%		Unreliability	10,0%	
MTBF (2000 W)	duty	0,5																						
35	735000	50% duty																						
35	735000	50%																						
Time	years	hours																						
	8,8	77440																						
Reliability	90%																							
Unreliability	10,0%																							
<ul style="list-style-type: none"> <li>- 8 years</li> <li>- 365 On/Off per year</li> <li>- Product On during 12h/day under all load and Ta: 35 °C</li> <li>- Product Off the rest of the time under Ta: 35 °C</li> <li>- Duty: 50%</li> <li>- C10 (MTBF): 8.8 years</li> </ul>																								
<b>Mission Profile B</b>		<table border="1"> <tr> <td>MTBF (2000 W)</td> <td>duty</td> <td>0,21</td> </tr> <tr> <td>45</td> <td>500000</td> <td>50% duty</td> </tr> <tr> <td>45</td> <td>1190476</td> <td>21%</td> </tr> <tr> <td>Time</td> <td>years</td> <td>hours</td> </tr> <tr> <td></td> <td>14,3</td> <td>125429</td> </tr> <tr> <td>Reliability</td> <td>90%</td> <td></td> </tr> <tr> <td>Unreliability</td> <td>10,0%</td> <td></td> </tr> </table>		MTBF (2000 W)	duty	0,21	45	500000	50% duty	45	1190476	21%	Time	years	hours		14,3	125429	Reliability	90%		Unreliability	10,0%	
MTBF (2000 W)	duty	0,21																						
45	500000	50% duty																						
45	1190476	21%																						
Time	years	hours																						
	14,3	125429																						
Reliability	90%																							
Unreliability	10,0%																							
<ul style="list-style-type: none"> <li>- 14 years</li> <li>- 313 On/Off per year.</li> <li>- Product On during 6 h/day under all load and Ta: 45 °C</li> <li>- Product Off the rest of the time under Ta: 45 °C</li> <li>- Duty: 21%</li> <li>- C10 (MTBF) = 14.3 years</li> </ul>																								
<b>Mission Profile C</b>		<table border="1"> <tr> <td>MTBF (2000 W)</td> <td>duty</td> <td>0,03</td> </tr> <tr> <td>45</td> <td>500000</td> <td>50% duty</td> </tr> <tr> <td>45</td> <td>8333333</td> <td>3%</td> </tr> <tr> <td>Time</td> <td>years</td> <td>hours</td> </tr> <tr> <td></td> <td>100</td> <td>878004</td> </tr> <tr> <td>Reliability</td> <td>90%</td> <td></td> </tr> <tr> <td>Unreliability</td> <td>10,0%</td> <td></td> </tr> </table>		MTBF (2000 W)	duty	0,03	45	500000	50% duty	45	8333333	3%	Time	years	hours		100	878004	Reliability	90%		Unreliability	10,0%	
MTBF (2000 W)	duty	0,03																						
45	500000	50% duty																						
45	8333333	3%																						
Time	years	hours																						
	100	878004																						
Reliability	90%																							
Unreliability	10,0%																							
<ul style="list-style-type: none"> <li>- 15 years</li> <li>- 40 On/Off per year</li> <li>- Product On during 6 h/day under all load and Ta: 45 °C</li> <li>- Product Off the rest of the time under Ta: 45 °C</li> <li>- Duty: 3%</li> <li>- (Product will be Off for 2 weeks and for up to 2 months once per year)</li> <li>- C10 (MTBF) = 100 years</li> </ul>																								







## ELECTROMAGNETIC COMPATIBILITY (EMC) – EMISSIONS

Phenomenon	Conditions / Notes	Standard	Performance Class
Conducted Emission	Test at 230/400 V <sub>AC</sub>	EN55015	
Radiated Emission	Test at 230/400 V <sub>AC</sub>	EN55015	
Conducted Emission	Test at 230/400 V <sub>AC</sub>	EN55032	Class B
Conducted and Radiated Emission	Test at 230/400 V <sub>AC</sub>	FCC CFR47- part 15/subpart B	Class B
Harmonic Current Emissions		EN61000-3-2	Class C (Load>25%)
Voltage Changes, Fluctuation and Flicker		EN61000-3-3	

## ELECTROMAGNETIC COMPATIBILITY (EMC) – IMMUNITY

Phenomenon	Conditions / Notes	Standard	Note
<b>Equipment for general lighting purposes - EMC Immunity Requirement</b>			
ESD (Electrostatic Discharge)		EN 61547	
Radiated Radio-Frequency electromagnetic field		EN 61000-4-2	
Electric Fast Transient / Burst		EN 61000-4-3	
Surge	Level ±10 kV L-L; ±10 kV L/L-PE	EN 61000-4-4	
Conducted disturbances induced by Radio-Frequency fields		EN 61000-4-5	
Voltage Dips, short interruptions and Voltage Variations		EN 61000-4-6	
Non-repetitive damped oscillatory transient, Ring wave	2.5 kV	EN 61000-4-11	ANSI C.62.41 Category A

## SAFETY AGENCIES APPROVALS

Agency	Standards	Mark
ENEC	IEC/EN 61347-2-13 electronic control gear for LED Module and IEC/EN 61347-1 IEC/EN 62384 DC or AC supplied electronic control gear for LED modules – Performance Requirements	
UL	UL Compliant ANSI / UL8750, CSA C22.2 No.250. LED Driver suitable for dry and damp location	
RCM	AS/NZS IEC 61347-2-3, AS/NZS 61347-1	 Available upon request
EU and UK Declaration of Conformity	CE and UKCA Declaration of Conformity	
CB Scheme	CB report as per IEC 61347-1, IEC 61347-2-13	
Emergency Lighting	IEC 61347-1, IEC / EN 61347-2-13, IEC / EN 61347-2-7, IEC / EN 62384 : 2020 The control gear is intended for operation in AC supply mode and for connection to a centralized emergency supply system tested in accordance with Annex J of IEC/EN 61347-2-13. The product does not contain a battery and must not be connected to a DC supply. The rated emergency supply voltage is 220–240 V / 400 V. The centralized supply system must be capable of providing this voltage for the control gear to supply power to the LED loads, where permitted by the installation system design and classification, and provided that the configuration is implemented in accordance with the installation instructions and within the specified operating conditions. The Emergency Output Factor (EOFx) is equal to 1 at the specified ambient temperature, for which the output current does not deviate from the set current by more than ±15%.	

The DLD2052-H120-DX is compliant with the requirements of China implementation rules CNCA-C09-01:2014 and the corresponding standards GB4943.1-2011; GB17625.1-2012; GB9254-2008 (Class A) as well as Australian / New Zealand RCM safety standards. Relevant certificates and marks can be achieved upon request.

Specifications appearing in ENEDO's catalogues and brochures as well as any oral statements are not binding. All descriptions, drawings and other particulars (including dimensions, materials and performance data) given by ENEDO are as accurate as possible but, being given for general information, and are not binding on ENEDO. ENEDO makes thus no representation or warranty as to the accuracy of such material. We assume no liability other than as agreed in the terms of the individual contracts and we reserve the right to make technical modifications in the course of our product development. Our product information solely describes our goods and services and is in no way to be construed or interpreted as a quality or condition guarantee. The aforesaid shall not relieve the customer of its obligation to verify the suitability of our Products for the use or application intended by the purchaser. Customers are responsible for their products and applications. ENEDO assumes no liability from the use of its products outside of specifications. No license is granted to any intellectual property rights by this document.